

BTUS BY MODEL

	DVLL48SP	DVLL60	DVLL72
Natural Gas	37,000	46,000	52,500
Propane	34,000	42,500	50,000

FRAMING DIMENSIONS

	DVLL48SP	DVLL48SP w/Outdoor Kit	DVLL60	DVLL72
A	51 3/4	51 3/4	49 3/8	61 5/8
B	68	68	79 5/8	91 5/8
C	19 1/2	21 1/4	21 1/2	21 1/2

Measurements given in inches. Dimensions may vary based on install. See manual.

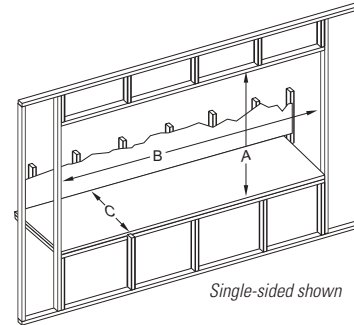

WARRANTY: 10-year Limited Warranty on Combustion Chamber, Limited Lifetime on Glass. All other parts carry a three-year limited warranty. All remote controls and lighting systems carry a one-year limited warranty.

Empire is committed to continuous product improvement; specifications are subject to change without notice. Dimensions in this brochure are approximate; read and follow the framing dimensions in the owners manual supplied with your Empire product.

Refer to your Owner's Manual for complete installation and safety information.

Authorized Dealer:

Member of the following industry associations:



This appliance is design-certified to the ANSI standard by:



SINCE 1932

918 Freeburg Avenue
Belleville, IL 62220
info@empirecomfort.com

www.empirecomfort.com

00983 2/17/20